

HVR800 High Voltage Relay Module

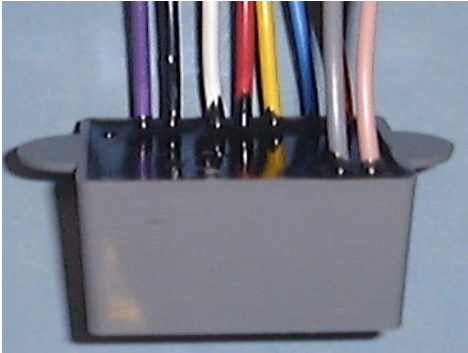

Fig. 1: HVR800 High Voltage Relay

Electromagnetic Compatibility

The HVR800 complies with the following:

- Product family standard EN50130-4 in respect of:
 - Conducted Disturbances,
 - Radiated Immunity,
 - Electrostatic Discharge,
 - Fast Transients
 - Slow High Energy
- EN61000-6-3 for emissions

Introduction



Version information

This document refers to HVR800s with a manufacturing date code of 43-03 or later. When used with a RIM800, RIM800 PCB must be Issue 9 or later. For earlier versions of HVR800, refer to TIB0496.

Technical specifications

Parameter	Value
System Compatibility	Use only with MX Fire Alarm Controllers
Environment	Indoor Application only
Operating Temperature	-25 °C to +70 °C
Storage Temperature	-40 °C to +80 °C
Operating Humidity	Up to 95 % non-condensing
Dimensions (HWD)	<ul style="list-style-type: none"> ■ Module: 26.5 x 42 x 74 mm ■ Boxed: 124.5 x 166.5 x 84.5 mm
Electrical Characteristics	Input Voltages: <ul style="list-style-type: none"> ■ 24 Vdc, 24 Vac, 120 Vac, 240 Vac ■ Contact Rating: 8A @ 28 Vdc ■ 10 A @28 Vac and 120 Vac 5 A @ 240 Vac (resistive)

Table 1: Technical Specifications

The HVR800 High Voltage Relay Interface is a non-addressable, multi-voltage relay module (operating from 24V dc, 24 V ac, 120 V ac and 240 V ac).

The encapsulated HVR800 provides a 10 amp volt-free contact that can be used to extend the contact ratings of the RIM800 Relay Interface Module applications.

A maximum of two HVR800s can be individually driven and controlled by an MIO800 Small Addressable Multi-Input/Output module if all HVR800s are powered by 24V dc or 24 V ac.

A maximum of four HVR800s can be individually driven and controlled by an MIO800 Small Addressable Multi-Input/Output module if all HVR800s are powered by 120 V ac or 240 V ac.

For ac operation, no external dc power supply unit is required to operate the relay.

When used to switch 24 V dc, the HVR800 must be provided with an external 24 V dc supply which should be switched through the clean relay contacts of an MIO800 or RIM800.

Features

The HVR800 is contained on a single-sided printed circuit board, which is fitted to a plastic tray and then potted (as Fig. 1 on page 1).

Mounting

The HVR800 may be mounted in any suitable electrical box or may be ordered as a boxed version. Terminal blocks complying with the EC Low Voltage Directive must be used when 120 V ac and 240 V ac voltages are used. A warning label must be fitted to the electrical box and RIM when mains voltages are used.

Use a single mains power source for each HVR800. Do not connect an HVR800 to multiple mains power sources or multiple points of the same mains power source.

In all 24V dc and 24V ac applications, all unused HVR800 wires must be individually isolated and insulated to prevent the risk of electrical shorting.



WARNING

In 120V ac and 240V ac applications, mains voltages (120V ac Or 240V ac) will be present on some of the unused wires. In all these applications all unused HVR800 wires must be individually isolated and insulated to prevent risk of electrical shorting and electric shock.



NOTICE

- There are no user required settings (such as switches or headers) on the HVR800.
- All wiring must conform to the current edition of IEE Wiring Regulations and BS5839 part 1.
- All conductors to be free of earths.
- For typical wiring configuration, see Figures 2 to 6.
- The GRY and PNK driver 'O' wires on the HVR800 must not be used in 24V dc and 24V ac applications.
- The HVR800 must be mounted adjacent the MIO800 or RIM800. The maximum cable length can not be greater than 1 metre between the HVR800 and the RIM800/RIM800.
- When connecting the HVR800 to the RIM800, wire the HVR pink and grey wires directly to the RIM800 O+ and O- terminals. Do not use additional wires. Run the wires through a ferrite choke and secure the choke as appropriate. Do not loop the wires through the choke.

Cabling

An approved low voltage terminal block must be used. Unused wires must be terminated in an approved manner.

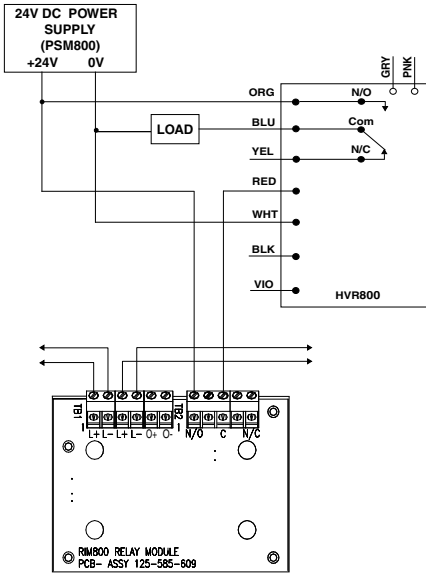

Fig. 2: HVR800 in 24 Vdc Application

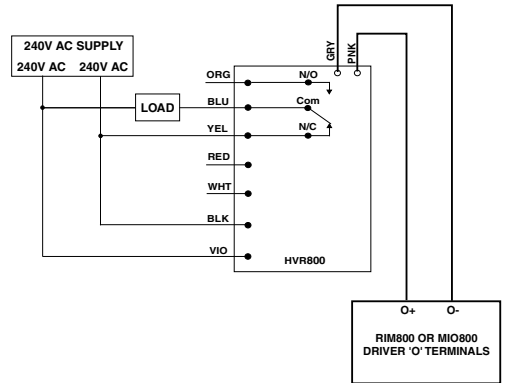

Fig. 3: HVR800 in 24 Vac Application



NOTICE

- All unused HVR800 wires must be individually isolated and insulated to prevent the risk of electrical shorting and electric shock.
- Connect load wire to ORG for a normally 'ON' load.



WARNING

In this application, 240V ac will be present on some of the unused wires of the HVR800.

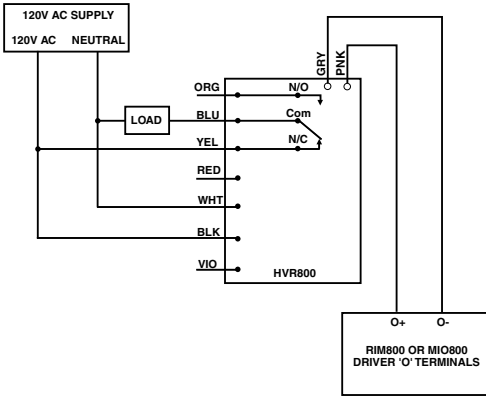

Fig. 4: HVR800 in 120 Vac Application



NOTICE

- All unused HVR800 wires must be individually isolated and insulated to prevent the risk of electrical shorting and electric shock.
- Connect load wire to ORG for a normally 'ON' load.



WARNING

In this application, 240V ac will be present on some of the unused wires of the HVR800.

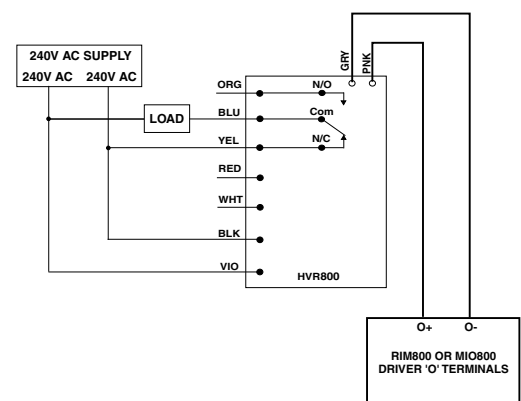

Fig. 5: HVR800 in 240 Vac Application



NOTICE

- All unused HVR800 wires must be individually isolated and insulated to prevent the risk of electrical shorting and electric shock.
- Connect load wire to ORG for a normally 'ON' load.



WARNING

In this application, 240V ac will be present on some of the unused wires of the HVR800.

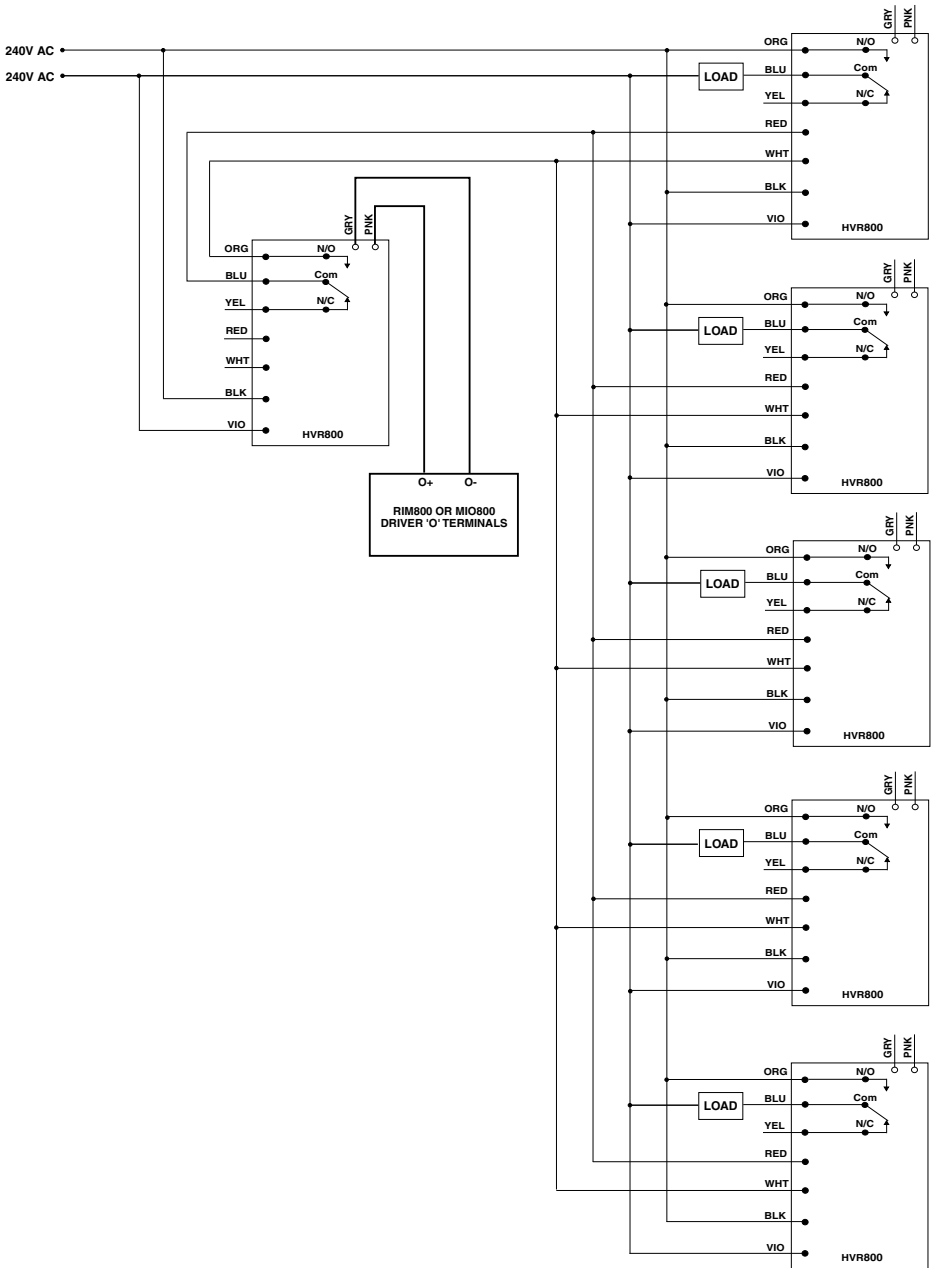



Fig. 6: Multiple HVR800s in 240V ac Application

Ordering information

Name	Stock code number
HVR800 High Voltage Relay Interface	568.800.004
HVR800 High Voltage Relay Interface Boxed:	568.800.034

Table 2: Ordering information

CPR Information

 
<p>Tyco Fire & Security GmbH Victor von Bruns-Strasse 21 8212 Neuhausen am Rheinfall Switzerland</p> <p>15 2831-CPR-F1630 21 0832-UKCA-CPR-F0134</p> <p>DoP-2015-4065</p>
<p>EN 54-18: 2005 Input-output device for use in fire detection and alarm systems in buildings HVR800</p>
<p>Essential Characteristics EN 54-18: 2005 Response delay (response time): Pass Performance under fire conditions: Pass Operational reliability: Pass Durability of operational reliability; temperature resistance: Pass Durability of operational reliability; vibration resistance: Pass Durability of operational reliability; humidity resistance: Pass Durability of operational reliability; corrosion resistance: Pass Durability of operational reliability; electrical stability: Pass</p>
<p>Fixing Instructions 120.415.528_17A-03-HVR Service Instructions 17A-04-S</p>